



INSTRUCTION MANUAL

COUPLING/DECOUPLING

NETWORK AF4

MODEL EM-7803-2

INSTRUCTION MANUAL

THIS INSTRUCTION MANUAL AND ITS ASSOCIATED INFORMATION IS PROPRIETARY. UNAUTHORIZED REPRODUCTION IS FORBIDDEN.

© 1996 ELECTRO-METRICS CORP.

COUPLING/DECOUPLING NETWORK AF-4

ELECTRO-METRICS

MODEL EM-7803-2

SERIAL NO: N/A

ELECTRO-METRICS CORPORATION

231 Enterprise Road, Johnstown, New York 12095
Phone: (518) 762-2600 Fax: (518) 762-2812

EMAIL: info@emihq.com

WEB: <http://www.electro-metrics.com>

MANUAL REV. NO: EM78032-0796

ISSUE DATE: JULY 01 1996

WARRANTY

This Model EM-7803-2 AF-4 Coupling/Decoupling Network AF-4 is warranted for a period of 12 months (USA only) from date of shipment against defective materials and workmanship. This warranty is limited to the repair of or replacement of defective parts and is void if unauthorized repair or modification is attempted. Repairs for damage due to misuse or abnormal operating conditions will be performed at the factory and will be billed at our commercial hourly rates. Our estimate will be provided before the work is started.

TABLE OF CONTENTS

SECTION	TITLE	PAGE
A-1	Appendix A: List Of Accessories	A-1
1.0	Introduction	1
2.0	Specifications	1
3.0	Description EM-7803-2	2
4.0	Operating Instructions	2
5.0	Reference Information	3

LIST OF ILLUSTRATIONS

FIGURE	TITLE	PAGE
1	Schematic Diagram EM-7803-2	4

APPENDIX 1
EM-7803-2 ACCESSORIES

The following accessories are standard with the **EM-7803-2 Coupling/Decoupling Network AF4**.

- a.** 50-ohm Termination, BNC Connector.
- b.** Eight (8) Banana Plug Connectors:
 - INPUT: 4
 - OUTPUT: 4
- c.** 50/150-ohm Impedance Matching Network.
 - Quantity: 2
- d.** 6 dB Attenuator

**DESCRIPTION AND USE
COUPLING/DECOUPLING NETWORK AF4
ELECTRO-METRICS MODEL EM-7803-2**

1.0 Introduction

The EM-7803-2 Coupling/Decoupling Network AF4 is a low pass filter network that allows coupling of RF signals onto the unshielded (unscreened) cabling of a device being tested to IEC-1000-4-6 (formerly IEC 801.6).

The EM-7803-2 is used for conducted susceptibility testing of 4-line unshielded cabling with nonbalanced lines. The network is designed to be fully compliant with IEC-1000-4-6.

Included with each unit, as required by IEC-1000-4-6:

- a. High power 6 dB attenuator, quantity: 1,
- b. 50/150-ohm matching networks, quantity: 2.

2.0 Specifications

2.1 Electrical

Injection Frequency Range:	150 kHz-80 MHz
Current:	1 Ampere AC/DC.
Voltage:	50 V AC/DC.
Injection Port Voltage:	20 Vrms.
Connectors:	Injection Port: BNC Input/Output: Banana Jack Connector
Grounding Connector:	Threaded Stud.

2.2 Mechanical

Height:	100 mm (3.95")
Length:	218 mm (8.6")
Over Ground Stud:	239 mm (9.4")
Width:	171 mm (6.75")
Weight:	1.5 kg (3.25 lbs)

3.0 Description EM-7803-2

The two end panels for the EM-7803-2 Network are marked:

- a. Auxiliary Equipment (AE),
- b. Equipment Under Test (EUT).

3.1 Auxiliary Equipment Panel

a. Input Connectors

Type: Banana Jack.

Quantity: 4.

Color: Red, Black, White, Blue.

Function: To connect to the 4-line unshielded cabling.

b. Ground Connector

Type: Brass Stud.

Quantity: 1.

Function: To connect to the ground plane or shielded enclosure.

3.2 Equipment Under Test Panel

a. Output Connectors

Type: Banana Jack.

Quantity: 4.

Color: Red, Black, White, Blue.

Function: To connect to the Equipment Under Test 4-line unshielded cabling input.

4.0 Operating Instructions

The AE (Auxiliary Equipment) panel of the network should be connected to the unshielded cabling using the four banana plugs provided. Attach these plugs to the banana jacks located on the AE panel. The ground connection should be made through the brass stud (marked GND) on the AE panel.

NOTE

A BRASS RF GROUND STUD IS PROVIDED ON THE AE PANEL FOR CONNECTION TO THE GROUND PLANE.

The EUT (Equipment Under Test) panel of the network should be connected to the device under test using the four banana plugs provided.

The RF test signal at the required level is applied to the BNC connector (top panel) on the EUT end of the network. The signal is normally applied through the 6 dB attenuator (supplied).

5.0 Reference Information

The design of the EM-7803-2 Coupling/Decoupling Network AF4 is based on the information contained in International Electrotechnical Commission Publication IEC 1000-4-6 (Para. 6.2).

The application and verification of the coupling/decoupling network is explained in detail by the IEC publication. For any questions concerning the use of the network, 50/150-ohm impedance matching network, or procedures to be followed refer to the IEC publication.

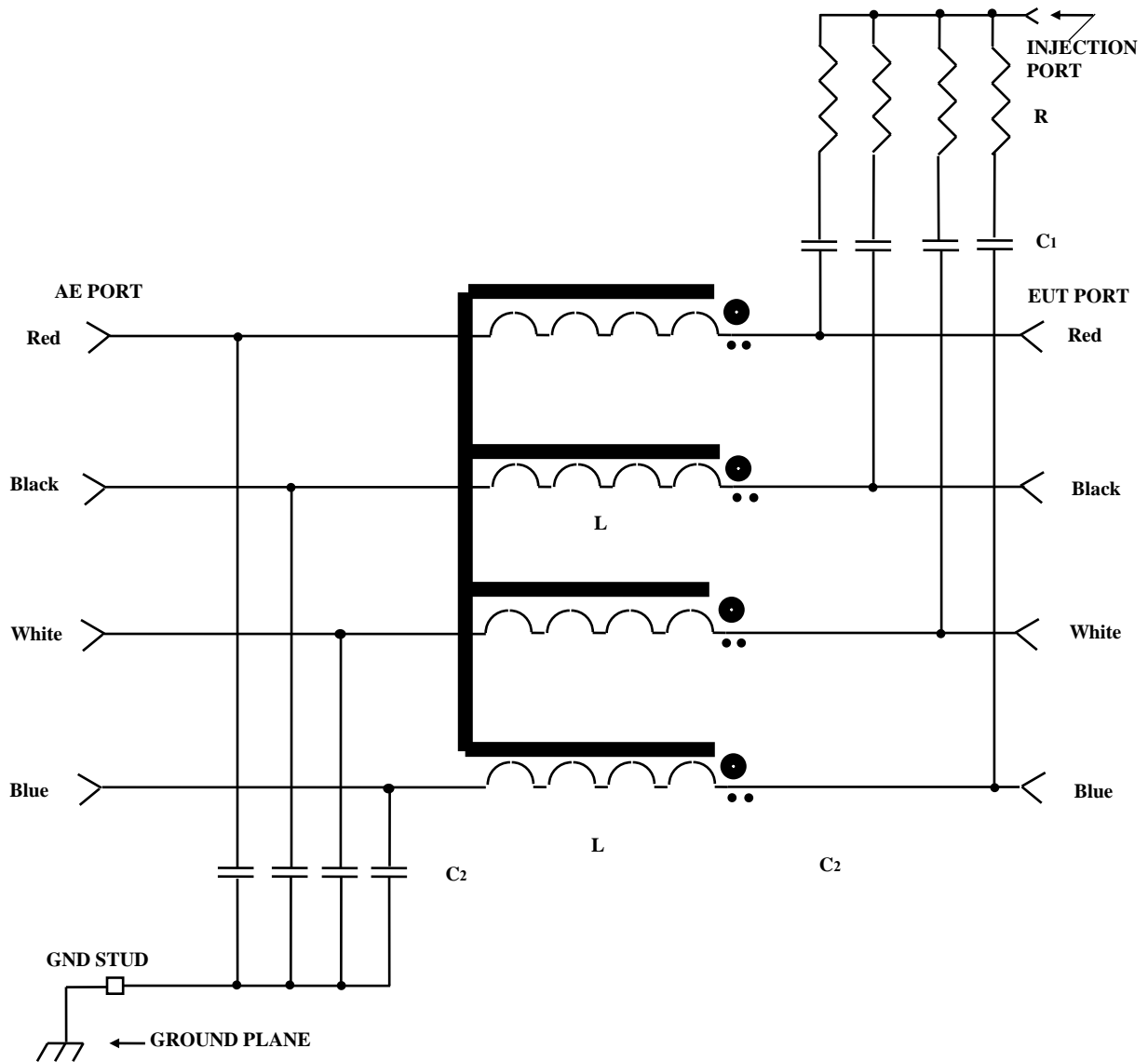

NOTE: $C_1 = 0.0056 \mu\text{F}$ (typ.), $C_2 = 0.047 \mu\text{F}$ (typ.), $R = 400 \Omega$, $L = 684 \mu\text{H}$
 Ferrite Beads - as required.

Figure 1

Schematic Diagram EM-7803-2 Coupling/Decoupling Network AF4