



INSTRUCTION MANUAL

COUPLING/DECOUPLING

NETWORK M3

MODEL EM-7801

INSTRUCTION MANUAL

THIS INSTRUCTION MANUAL AND ITS ASSOCIATED INFORMATION IS PROPRIETARY. UNAUTHORIZED REPRODUCTION IS FORBIDDEN.

© 1996 ELECTRO-METRICS CORP.

COUPLING/DECOUPLING NETWORK M3

ELECTRO-METRICS

MODEL EM-7801

SERIAL NO: N/A

ELECTRO-METRICS CORPORATION

231 Enterprise Road, Johnstown, New York 12095

Phone: (518) 762-2600

Fax: (518) 762-2812

EMAIL: info@emihq.com

WEB: <http://www.electro-metrics.com>

MANUAL REV. NO: EM7801-0796

ISSUE DATE: JULY 01 1996

WARRANTY

This Model EM-7801 Coupling/Decoupling Network M3 is warranted for a period of 12 months (USA only) from date of shipment against defective materials and workmanship. This warranty is limited to the repair of or replacement of defective parts and is void if unauthorized repair or modification is attempted. Repairs for damage due to misuse or abnormal operating conditions will be performed at the factory and will be billed at our commercial hourly rates. Our estimate will be provided before the work is started.

TABLE OF CONTENTS

SECTION	TITLE	PAGE
A-1	Appendix A: List Of Accessories	A-1
1.0	Introduction	1
2.0	Specifications	1
3.0	Description EM-7801	2
4.0	Operating Instructions	2
5.0	Reference Information	3

LIST OF ILLUSTRATIONS

FIGURE	TITLE	PAGE
1	Schematic Diagram EM-7801	4

APPENDIX 1 EM-7801 ACCESSORIES

The following accessories are standard with the **EM-7801 Coupling/Decoupling Network M3**.

- a. 50-ohm Termination, BNC Connector.
- b. Six (6) Superior Plug/Pin Connectors:
 - INPUT: 3
 - OUTPUT: 3
- c. 50/150-ohm Impedance Matching Network.
 - Quantity: 2
- d. 6 dB Attenuator

**DESCRIPTION AND USE
COUPLING/DECOUPLING NETWORK M3
ELECTRO-METRICS MODEL EM-7801**

1.0 Introduction

The EM-7801 Coupling/Decoupling Network M3 is a low pass filter network that allows coupling of RF signals onto the power lines of a device being tested to IEC-1000-4-6 (formerly IEC 801.6).

The EM-7801 is used for conducted susceptibility testing of devices powered by a single phase with two or three power input wires. The network is designed to be fully compliant with IEC-1000-4-6.

Included with each unit, as required by IEC-1000-4-6:

- a. High power 6 dB attenuator, quantity: 1,
- b. 50/150-ohm matching networks, quantity: 2.

2.0 Specifications

2.1 Electrical

Injection Frequency Range:	150 kHz-80 MHz
Power Line Frequency:	DC to 60 Hz.
AC Current:	25 Ampere rms.
AC Voltage:	250 Vrms.
Injection Port Voltage:	20 Vrms.
Connectors:	Injection Port: BNC AC Input/Output: Superior Plug/Socket
Grounding Connector:	Threaded Stud.

2.2 Mechanical

Height:	100 mm (3.95")
Length:	218 mm (8.6")
Over Ground Stud:	239 mm (9.4")
Width:	171 mm (6.75")
Weight:	1.5 kg (3.25 lbs)

3.0 Description EM-7801

The two end panels for the EM-7801 Network are marked:

- a. Auxiliary Equipment (AE),
- b. Equipment Under Test (EUT).

3.1 Auxiliary Equipment Panel

a. AC Connectors

Type: Socket Receptacle, Superior Type RS.

Quantity: 3.

Color:

- 1) **Red (LINE):** AC Input line.
- 2) **Black (NEUTRAL):** AC Return line.
- 3) **Green (EARTH):** Ground line.

Function: To connect to the power source either directly or via other equipment.

b. Ground Connector

Type: Brass Stud.

Quantity: 1.

Function: To connect to the ground plane or shielded enclosure.

3.2 Equipment Under Test Panel

a. AC Connectors

Type: Pin Receptacle, Superior Type RP.

Quantity: 3.

Color:

- 1) **Red (LINE):** AC Output line.
- 2) **Black (NEUTRAL):** AC Return line.
- 3) **Green (EARTH):** Ground line.

Function: To connect to the Equipment Under Test AC power input.

4.0 Operating Instructions

The AE (Auxiliary Equipment) panel of the network should be connected to the power source (either direct or via other equipment) using the three plug sockets provided (Superior Plug Sockets). Attach these plugs to the pin receptacles located on the AE panel. The ground connection should be made through the ground receptacle (marked EARTH) or a brass stud (marked GND), both located on the AE panel.

WARNING

SAFETY GROUND SHOULD BE CONNECTED FIRST AND DISCONNECTED LAST ON INPUT OR AE SIDE OF NETWORK.

NOTE

A BRASS RF GROUND STUD IS PROVIDED ON THE AE PANEL FOR CONNECTION TO THE GROUND PLANE.

The EUT (Equipment Under Test) panel of the network should be connected to the device under test using the two pin plugs provided. If the device under test uses a ground contact as the third wire of the power connection, it may be made through the ground receptacle (marked EARTH) on the EUT panel.

The RF test signal at the required level is applied to the BNC connector (top panel) on the EUT end of the network. The signal is normally applied through the 6 dB attenuator (supplied).

5.0 Reference Information

The design of the EM-7801 Coupling/Decoupling Network M3 is based on the information contained in International Electrotechnical Commission Publication IEC 1000-4-6 (Para. 6.2).

The application and verification of the coupling/decoupling network is explained in detail by the IEC publication. For any questions concerning the use of the network, 50/150-ohm impedance matching network, or procedures to be followed refer to the IEC publication.

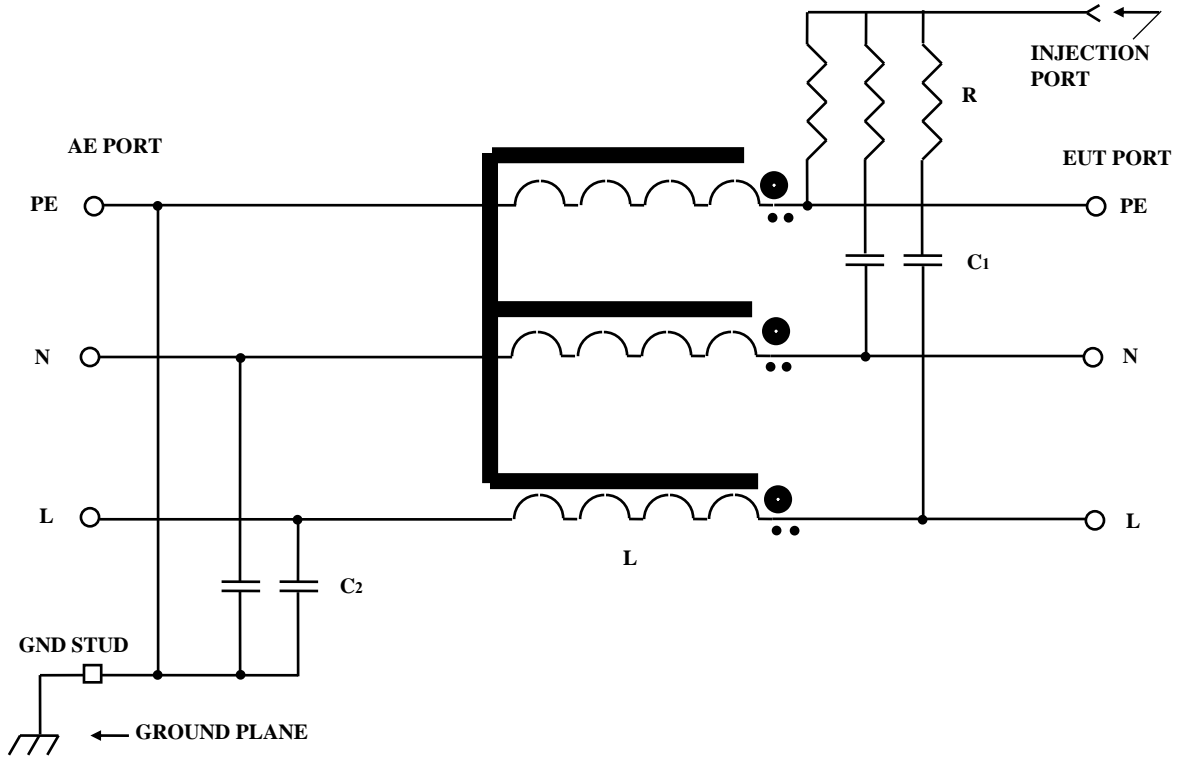

NOTE: $C_1 = 0.01 \mu\text{F}$ (typ.), $C_2 = 0.047 \mu\text{F}$ (typ.), $R = 300 \Omega$, $L = 684 \mu\text{H}$
 Ferrite Beads - as required.

Figure 1

Schematic Diagram EM-7801 Coupling/Decoupling Network M3